

Power Electronics Testings

PV Inverter Test Solution

www.chromaate.com



Chroma

Turnkey Test & Automation Solution Provider



A PV system is an energy system which directly converts energy from the sunlight into electricity. Once light hits the solar cell (array), electricity is generated and the DC is collected at a PV inverter.

PV inverter is a device that changes DC power to AC power and is also a key component in PV systems. There are two main types of PV systems, Grid Connected or Off Grid. Grid connected systems are usually installed on a building and provide electricity directly into the mains supply. Off grid systems are usually used where power is required but access to a mains supply is unavailable.

Chroma provides PV inverter testing solutions based on its thirty years of experience in power electronics testing. These solutions include:

- 1. DC Power Supply 62000H-S Series** : to simulate output characteristics of the solar array. It also provides a unique feature called solar array simulation function. This function is useful for MPPT performance evaluation on PV inverter devices.
- 2. Digital Power Meter 66200 Series** : to measure PV inverter output parameters, such as V, I, P, PF, current harmonics & THD.
- 3. AC Power Source 6500/61500/61800 Series** : to simulate mains power various scenarios.
- 4. AC Load 63800 Series** : to sink current directly for off grid type PV inverters. The Chroma AC Source provides a voltage level as the reference for the PV inverter output. But the AC source can not sink current (energy); therefore, an external resistor is necessary for load simulation. Chroma also provides Automated Test Systems suitable for R&D, QA qualification and mass production.

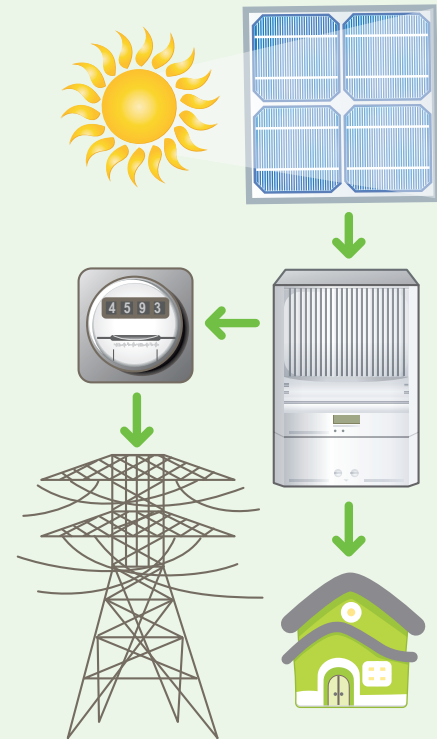

Grid Connected Type Testing

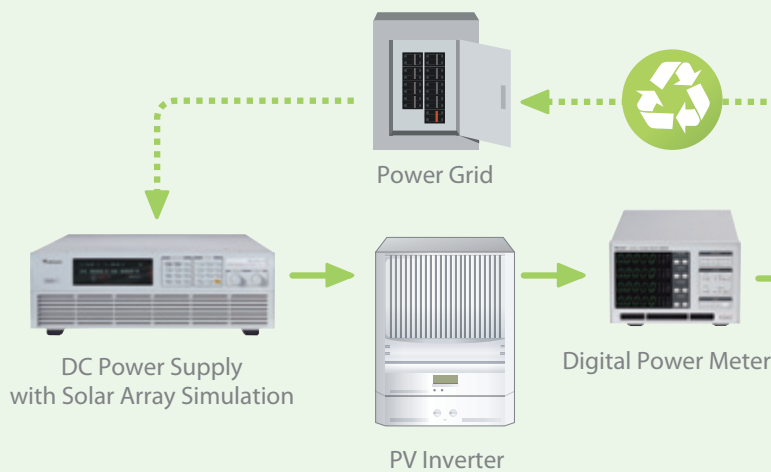

Stand Alone (Off Grid) Type Testing



Programmable DC Power Supplies with Solar Array Simulation

Model 62000H-S Series

Key Features

- ✓ Voltage range : 0 ~150V/600V/1000V
- ✓ 3U/15kW high power density module with easy master/slave parallel operation up to 1.5MW
- ✓ Simulation of multiple solar cell material's I-V characteristic (fill factor)
- ✓ Simulation of dynamic irradiation intensity and temperature level from clear day to cloud cover conditions
- ✓ Shadowed I-V curve output simulation up to 4096 data points
- ✓ Auto I-V program: 100 I-V curves & Dwell time 1-15,000s
- ✓ Static & dynamic MPPT efficiency test
- ✓ Support up to six-channel SAS control for multi-MPPT testing

The latest programmable solar array simulator power supply 62000H-S released by Chroma provides simulation of Voc (open circuit voltage) up to 1000V and Isc (short circuit current) up to 25A. The 62000H-S provides an industry leading power density in a small 3U high package. The solar array simulator is highly stable and has a fast transient response design, which are both advantage to MPPT performance evaluation on PV inverter devices. The Model 62020H-150S provides high precision and fast response of SAS for micro-inverter and solar charger testing.

Static & Dynamic MPPT Efficiency Testing

The model 62000H-S includes a graphical user Interface software through remote digital interface (USB/GPIB/Ethernet/RS232) control. The user can easily program the I-V curve of the 62000H-S as well as the I-V & P-V curve for real-time testing. In addition it will display the MPPT status for the PV inverter. Readings and the report function with real-time monitoring using the Softpanel are shown below.



62020H-150S



62150H-1000S



150kW Solar Array Simulator



EN50530, Sandia & CGC/GF004 (NB/T 32004-2013) Dynamic MPPT Test



Static MPPT Test

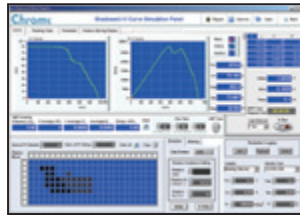

Shadowed I-V Curve Simulation

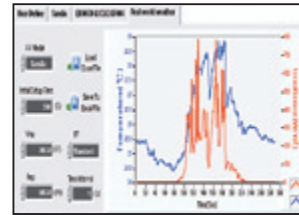

Real World Weather Simulation

Model	62020H-150S	62050H-600S	62100H-600S	62150H-600S/1000S
Output Ratings				
Output Voltage	0~150V	0~600V	0~600V	0~600V/0~1000V
Output Current	0~40A	0~8.5A	0~17A	0~25A/15A
Output Power	2kW	5kW	10kW	15kW

Note 1 : Minimum output voltage is <0.15% of rate voltage at zero output setting.

Note 2 : Minimum output current is <0.2% of rate current at zero output setting when measured with rated load resistance.

* Call for more information on customization of high power system >150kW

High Precision Power Measurement Digital Power Meters

Model 66200 Series

Key Features

- ✓ Voltage Ranges : 15/30/60/150/300/600 Vrms (66203/66204)
- ✓ Current Ranges : 0.005/0.02/0.05/0.2/0.5/2/5/20 Arms (66203/66204)
- ✓ Other : Current Harmonics & THD
- ✓ Support 1P2W/1P3W/3P3W/3P4W wiring mode (66203, 3CH/66204, 4CH)
- ✓ Support ultra high precision DCCT 60A/200A optional kit for high current measurement application



66200 Softpanel



66200 Softpanel



IEC 61000-3-2 Current Harmonic Test (Pre-compliance)



Power Efficiency Test Softpanel



66201/66202



66203/66204

Model	66202	66203/66204
Parameters	V, Vpk, I, Ipk, Is, W, VA, VAR, PF, CF_I, F, THD_V, THD_I, Energy	V, Vpk, I, Ipk, Is, W, VA, VAR, PF, CF_I, F, THD_V, THD_I, Energy
AC/DC Voltage	150/300/500Vrms (CF = 1.6)	15V/30V/60V/150V/300V/600Vrms (CF=2), 6 range HV option up to 1200Vrms
AC/DC Current	SHUNT H : 0.2/2/8/20Arms (CF=2@0.2/2/8A, CF = 4@ 20A) SHUNT L : 0.01/0.1/0.4/2Arms (CF=4)	5mA/20mA/50mA/200mA/500mA/2A/5A/20Arms (CF=4)
Power	47Hz ~ 63Hz : 0.1% of rdg + 0.1% of rng 15Hz ~ 1KHz : (0.1 + 0.2/PF x KHz)% of rdg + 0.18% of rng For EN 50564 (300V x 100mA range) 0.1% of rdg + 0.05% of rng	DC, 47Hz to 63Hz : 0.1% RD + 0.1% RNG 10Hz to 1KHz : 0.1% RD + 0.18% RNG 1KHz to 10KHz : (0.1+0.1 x kHz)% RD + 0.18% RNG



Advance AC Power Sources

Model 61500/61800/6500 Series

Key Features

- ✓ Output : 500VA~300KVA/0~300VAC/424VDC, 1 or 3 phase
- ✓ Turn on, turn off phase angle control
- ✓ Programmable voltage and frequency slew rate
- ✓ Power line disturbance simulation LIST, PULSE, STEP modes
- ✓ Distortion waveform editor SYNTH and INTERHAR modes
- ✓ Measurement for RMS Voltage, Current, Power, PF, VA, VAR, Crest factor, peak and inrush current
- ✓ Standard AC source for IEC61000-3-2 testing
- ✓ Full 4 quadrant, fully regenerative up to 100% of output current rating (61800 Series)
- ✓ Provide $400V_{LN}$ output voltage function (61800 Series option)
- ✓ Specially designed for PV inverter, smart grid and EV related test applications
- ✓ Meet IEEE 1547, IEC 61000-3-15, IEC 62116 standard test requirements
- ✓ Meet low voltage ride through LVRT test requirements

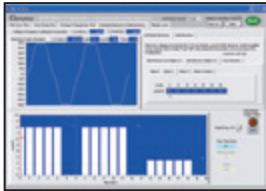

Voltage Harmonic & Interharmonics Test



Voltage DIP, Short, Variation Regulation Test



Programmable AC Power Source
61500 Series



Regenerative Grid Simulator
61800 Series

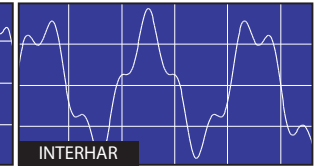
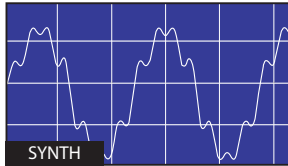
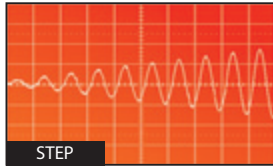
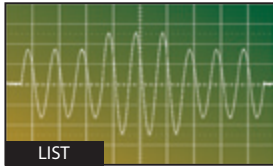
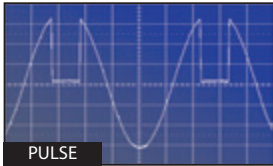

Model	6560	6590	61511	61512	61830/61845/61860
Output Phase	1	1 or 3	1 or 3	1 or 3	1 or 3
Power	6KVA	9KVA	12KVA	18KVA	30/45/60KVA
Voltage	150V/300V/500V	150V/300V	150V/300V	150V/300V	300V
Max. Current	60A/30A/15A	90A/45A	96A/48A	144A/72A	150A/225A/300A
Frequency	45 ~ 1KHz	45 ~ 1KHz	DC, 15 ~ 1.5KHz	DC, 15 ~ 1.5KHz	DC, 30 ~ 100Hz

Programmable AC Electronic Loads

Model 63800 Series

The 63800 Series AC&DC Electronic Loads are designed for testing Off-Grid Inverters. The 63800's state of the art design uses DSP technology to simulate non-linear rectified loads with it's unique RLC operating mode.

Key Features

- ✓ Phase : 1 or 3 (parallel)
- ✓ Power : 1.8KW, 3.6KW, 4.5KW
- ✓ Frequency : 45Hz ~ 440Hz
- ✓ Voltage : 50 ~ 350Vrms
- ✓ Power Factor : 0 ~ 1 lead or lag
- ✓ Crest Factor : 1.414 ~ 5
- ✓ Mode : CC, CR, CP, RLC



Model	63802	63803	63804
Power	1800W	3600W	4500W
Current	0 ~ 18Arms (54 Apeak, continue)	0 ~ 36Arms (108 Apeak, continue)	0 ~ 45Arms (135 Apeak, continue)
Voltage	50 ~ 350Vrms (500 Vpeak)	50 ~ 350Vrms (500 Vpeak)	50 ~ 350Vrms (500 Vpeak)
Frequency	45 ~ 440Hz, DC	45 ~ 440Hz, DC	45 ~ 440Hz, DC

High Performance Hardware Devices and Software Architecture

PV Inverter Automated Test Systems

Model 8000



- 1. Dummy Load & Controller**
- 2. Monitor**
- 3. AC Source** : Chroma 6500/61500/61600/61800 series
- 4. Digital Storage Oscilloscope** : TEK DPO/TDS series
- 5. System Controller** : Industrial PC
- 6. Digital Power Meter** : Chroma 66200 series
- 7. System Power Panel**
- 8. Connecting Panel**
- 9. DC Power Supply** : 62000H-S series
- 10. RLC Load** : Chroma A800067





Grid Connected PV Inverter Test Block Diagram

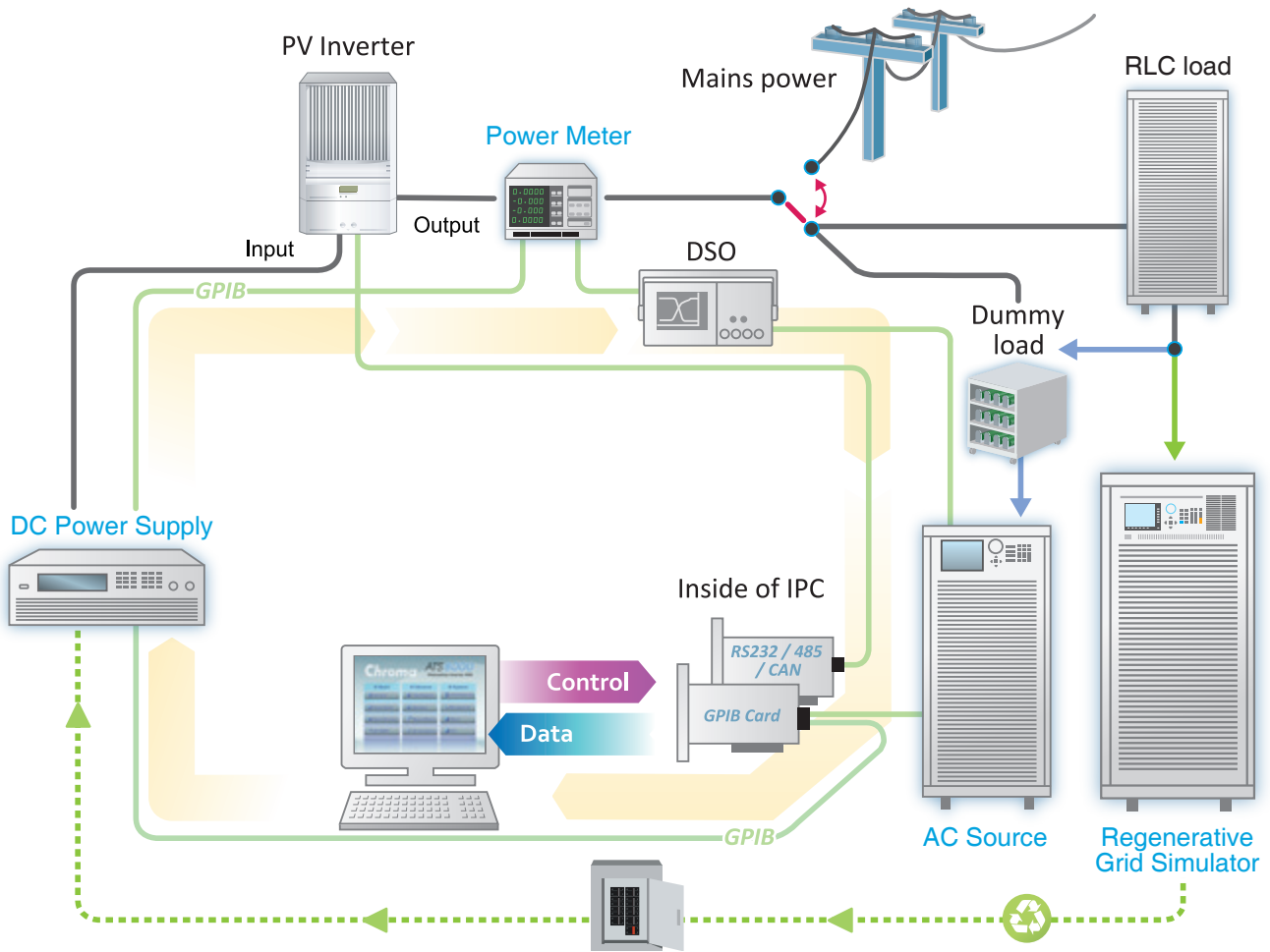

Off Grid PV Inverter Test Block Diagram

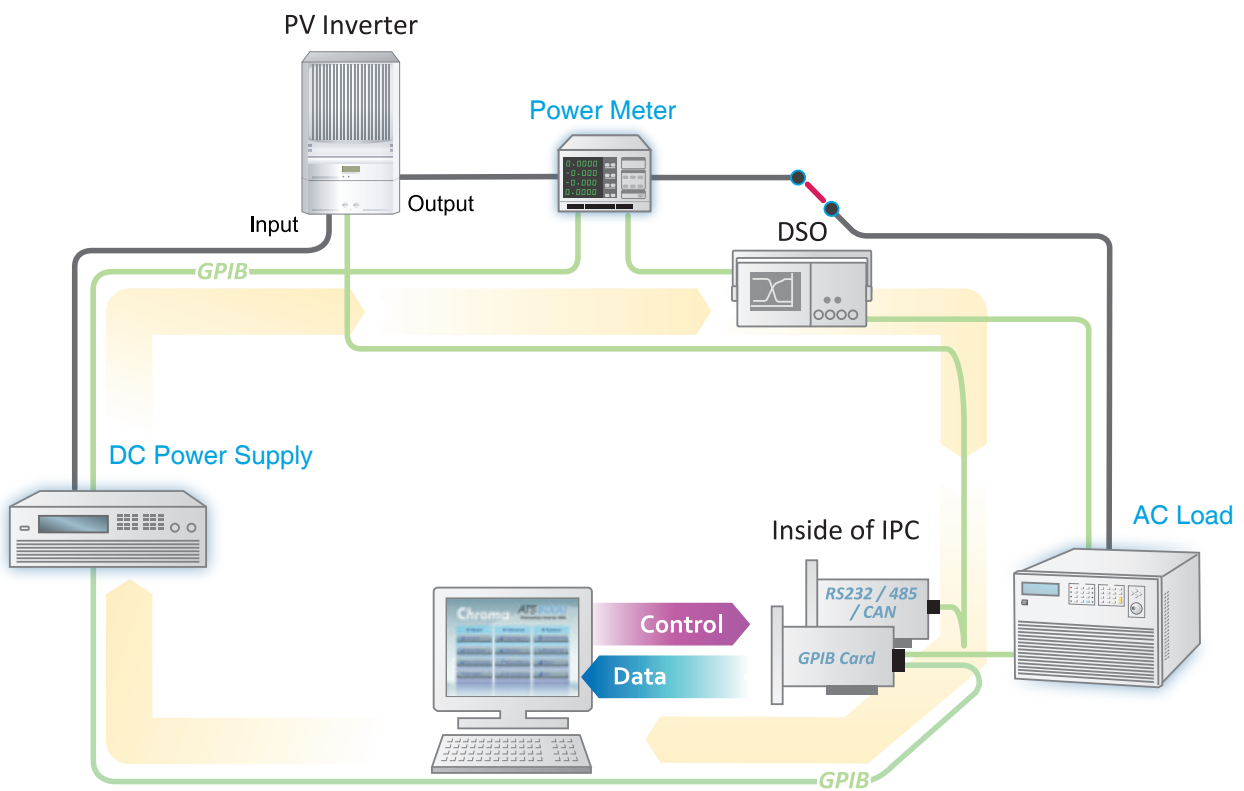

Optimized Equipment & Test Items

The Chroma 8000 ATS is equipped with optimized standard test items for PV inverters (the Unit Under Test), It meets EN50530, Sandia Lab, IEEE1547, 1547.1, UL 1741, GB/T 19939, and CGC/GF004 (NB/T 32004-2013) preliminary test requirements. The user is only required to define the test conditions and specifications for the standard test items to perform the test.

The optimized test item covers 5 types of power supply test requirements. The OUTPUT PERFORMANCE test verifies the output characteristics of the UUT. The INPUT CHARACTERISTIC test checks the UUT input parameters. TIMING & TRANSIENT tests the timing and transient states during protection. The PROTECTION TESTS trigger and test the protection circuit, the SPECIAL TEST provides means to test the most sophisticated UUT when unique test routines are needed.

Output Performances

1. Output Voltage
2. Output Current
3. Output Power
4. Output Power Factor
5. EFF (CEC/European/Conversion/Max)
6. DC injection Current
7. THD
8. Current Harmonic Test
9. Night Time Power Consumption

Input Characteristics

10. Input Voltage
11. Input MPPT Voltage
12. Input Current
13. Input Power
14. Input MPPT Power

Timing & Transient

15. OVP/UVF Trip Time
16. OFP/UFV Trip Time
17. Anti-Islanding Trip Time *
18. Re On-Grid Time

Special Tests

22. MPPT Efficiency
23. MPPT Time
24. MPPT Record
25. RS232/485/CAN communication

Protection Tests

19. OV/UV Protection
20. OF/UF Protection
21. Anti-Islanding *

* The A800067 RLC load is required. This system can test automatically and meet regulations of multiple anti-islanding protection test conditions to save test time. It not only fits R&D and QC, but also very suitable for production line.

Software Platform of ATS

The Model 8000 Test Systems include the industries most sophisticated power supply testing software platform, PowerPro III. PowerPro III provides users with an open software architecture suited for a wide range of applications and devices.

Power Pro III is a Windows 98/NT/2000/XP environment, which provides necessary computer peripherals.



Software Main Screen

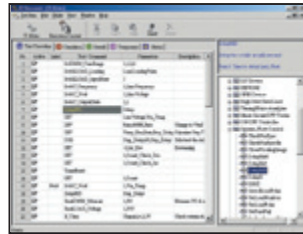

Test Item Editing

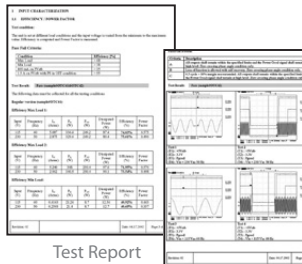

Test Report

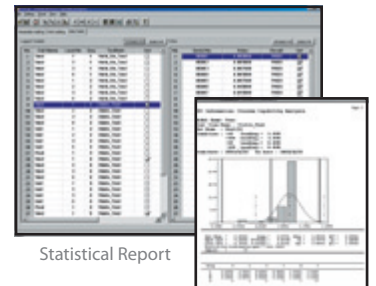

Statistical Report

Ordering Information

Programmable DC Power Supplies

62000H-S : Programmable DC Power Supply

Digital Power Meters

66202 : Digital Power Meter (1CH)

66203 : Digital Power Meter (3CH)

66204 : Digital Power Meter (4CH)

Programmable AC Electronic Loads

63800 : Programmable AC Electronic Load

Programmable AC Power Sources

6500 : Programmable AC Source

61500 : Programmable AC Source

61600 : Programmable AC Source

61800 : Regenerative Grid Simulator

PV Inverter Automatic Test Systems

8000 : PV Inverter ATS

A800066 : PV Inverter ATS Software

A800067 : RLC Load





**HEADQUARTERS
CHROMA ATE INC.**

66 Huaya 1st Road, Guishan, Taoyuan 33383, Taiwan
T +886-3-327-9999
F +886-3-327-8898
info@chromaate.com
www.chromaate.com

**CHINA
CHROMA ELECTRONICS (SHENZHEN) CO., LTD.**

8F, No.4, Nanyou Tian An Industrial Estate,
Shenzhen, China PC: 518052
T +86-755-2664-4598
F +86-755-2641-9620
www.chroma.com.cn

**JAPAN
CHROMA JAPAN CORP.**

472 Nippa-cho, Kouhoku-ku, Yokohama-shi,
Kanagawa, 223-0057 Japan
T +81-45-542-1118
F +81-45-542-1080
info@chroma.co.jp
www.chroma.co.jp

**U.S.A.
CHROMA SYSTEMS SOLUTIONS, INC.**

19772 Pauling, Foothill Ranch, CA 92610
T +1-949-600-6400
F +1-949-600-6401
sales@chromausa.com
www.chromausa.com

**U.S.A.
CHROMA ATE INC. (U.S.A.)**

7 Chrysler Irvine, CA 92618
T +1-949-421-0355
F +1-949-421-0353
Toll Free +1-800-478-2026
info@chromaus.com
www.chromaus.com

**EUROPE
CHROMA ATE EUROPE B.V.**

Morsestraat 32, 6716 AH Ede, The Netherlands
T +31-318-648282
F +31-318-648288
sales@chromaeu.com
www.chromaeu.com